

CMS3586A6-HF

N and P-Channel
RoHS Device
Halogen Free

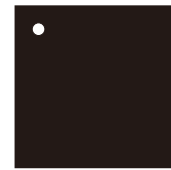

Features

- Simple drive requirement.
- Low gate charge.
- Low on-resistance.
- Fast switching speed.

Mechanical data

- Case: DFN2X2-6L, molded plastic.

Circuit Diagram

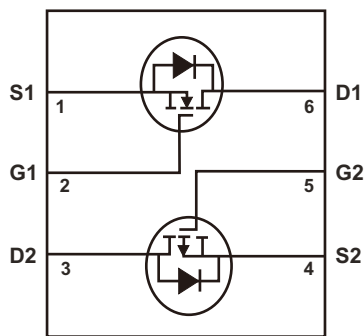

G: Gate S: Source D: Drain

- Pin 1. Source1 (S1)
- Pin 2. Gate1 (G1)
- Pin 3. Drain2 (D2)
- Pin 4. Source2 (S2)
- Pin 5. Gate2 (G2)
- Pin 6. Drain1 (D1)

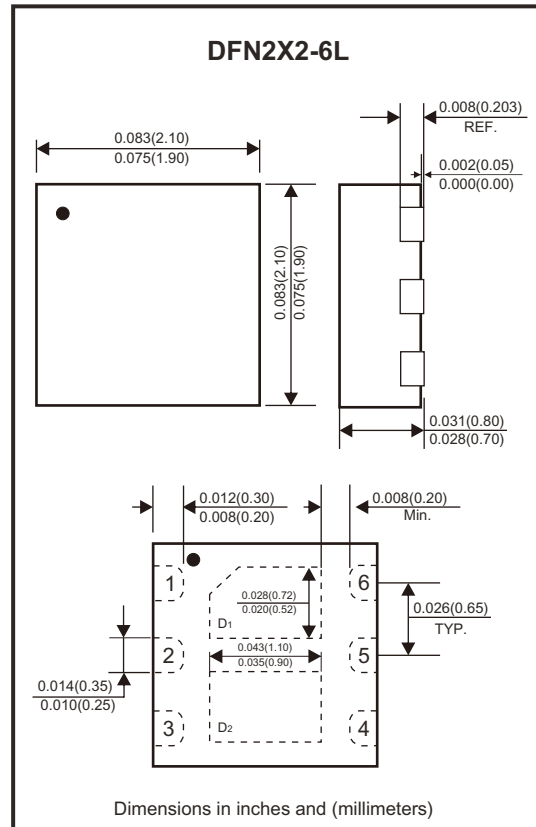

Maximum Ratings (at TA=25°C unless otherwise noted)

Parameter	Symbol	N-Channel	P-Channel	Unit	
Drain-source breakdown voltage	V _{DS}	20	-20	V	
Gate-source voltage	V _{GS}	±12	±12	V	
Continuous drain current	T _A =25°C (Note 1)	I _D	5	-3.3	A
	T _A =70°C (Note 1)	I _D	4	-2.6	A
Pulsed drain current (Note 2)	I _{DM}	20	-20	A	
Total power dissipation (Note 1)	P _D	1.38		W	
Linear derating factor		0.01		W/°C	
Maximum thermal resistance	Junction to case	R _{θJC}	80	°C/W	
	Junction to ambient (Note 3)	R _{θJA}	90		
Operating junction temperature range	T _J	-55 to +150		°C	
Storage temperature range	T _{STG}	-55 to +150		°C	

Note: 1. Surface mounted on 1 in² copper pad of FR-4 board, t≤5 sec.

2. Pulse width limited by maximum junction temperature.

3. Surface mounted on 1 in² copper pad of FR-4 board, t≤5 sec; 195°C/W when mounted on minimum copper pad.

Company reserves the right to improve product design, functions and reliability without notice.

REV:B

N-Channel Electrical Characteristics (at TA=25°C unless otherwise noted)

Parameter	Symbol	Conditions	Min	Typ	Max	Unit
Static						
Drain-source breakdown voltage	BV _{DSS}	V _{GS} = 0V, I _D = 250μA	20			V
Temperature coefficient of breakdown voltage	ΔBV _{DSS} /ΔT _J	Reference to 25°C, I _D = 1mA		0.02		V/°C
Gate-source threshold voltage	V _{GS(th)}	V _{DS} = V _{GS} , I _D = 250μA	0.5	0.7	1.2	V
Gate-source leakage	I _{GSS}	V _{GS} = ±12V, V _{DS} = 0			±100	nA
Zero gate voltage drain current	I _{DSS}	V _{DS} = 20V, V _{GS} = 0			1	μA
	I _{DSS}	V _{DS} = 16V, V _{GS} = 0, T _J = 70°C			10	μA
Drain-source on-state resistance	* R _{DS(on)}	I _D = 3.5A, V _{GS} = 4.5V		27	40	mΩ
		I _D = 1.2A, V _{GS} = 2.5V		37	50	
		I _D = 0.5A, V _{GS} = 1.5V		82	105	
Forward transconductance	* G _{FS}	V _{DS} = 5V, I _D = 3A		7		S
Dynamic						
Input capacitance	C _{iss}	V _{DS} = 20V, V _{GS} = 0V, f = 1MHz		423		pF
Output capacitance	C _{oss}			50		
Reverse transfer capacitance	C _{rss}			48		
Turn-on delay time	* t _{d(on)}	V _{DS} = 15V, I _D = 1A, V _{GS} = 5V, R _G = 3.3Ω, R _D = 15Ω		6		nS
Turn-on rise time	* t _r			8		
Turn-off delay time	* t _{d(off)}			11		
Turn-off fall time	* t _f			10		
Total gate charge	* Q _g	V _{DS} = 16V, I _D = 3A, V _{GS} = 4.5V		6		nC
Gate-source charge	* Q _{gs}			0.8		
Gate-drain charge	* Q _{gd}			2.5		
Source-Drain Diode						
Diode forward voltage	* V _{SD}	I _S = 1.2A, V _{GS} = 0V		0.77	1.2	V

* Pulse test: Pulse width ≤ 300μs, Duty cycle ≤ 2%.

P-Channel Electrical Characteristics (at TA=25°C unless otherwise noted)

Parameter	Symbol	Conditions	Min	Typ	Max	Unit
Static						
Drain-source breakdown voltage	BV _{DSS}	V _{GS} = 0V, I _D = -250μA	-20			V
Temperature coefficient of breakdown voltage	ΔBV _{DSS} /ΔT _J	Reference to 25°C, I _D = -1mA		-0.01		V/°C
Gate-source threshold voltage	V _{GS(th)}	V _{DS} = V _{GS} , I _D = -250μA		-0.8	-1.2	V
Gate-source leakage	I _{GSS}	V _{GS} = ±12V, V _{DS} = 0			±100	nA
Zero gate voltage drain current	I _{DSS}	V _{DS} = -20V, V _{GS} =0			-1	μA
	I _{DSS}	V _{DS} = -16V, V _{GS} = 0, T _J = 70°C			-25	μA
Drain-source on-state resistance	* R _{DS(on)}	I _D = -2.5A, V _{GS} = -4.5V		78	105	mΩ
		I _D = -2A, V _{GS} = -2.5V		115	150	
		I _D = -0.5A, V _{GS} = -1.5V		280	350	
Forward transconductance	* G _{FS}	V _{DS} = -5V, I _D = -2A		5		S
Dynamic						
Input capacitance	C _{iss}	V _{DS} = -20V, V _{GS} = 0V, f = 1MHz		429		pF
Output capacitance	C _{oss}			45		
Reverse transfer capacitance	C _{rss}			41		
Turn-on delay time	* t _{d(on)}	V _{DS} = -10V, I _D = -1A, V _{GS} = -10V, R _G = 3.3Ω, R _D = 10Ω		6		nS
Turn-on rise time	* t _r			17		
Turn-off delay time	* t _{d(off)}			16		
Turn-off fall time	* t _f			5		
Total gate charge	* Q _g	V _{DS} = -16V, I _D = -2A V _{GS} = -4.5V		6		nC
Gate-source charge	* Q _{gs}			0.8		
Gate-drain charge	* Q _{gd}			2.4		
Source-Drain Diode						
Diode forward voltage	* V _{SD}	V _{GS} = 0V, I _S = -1.2A		-0.82	-1.2	V

* Pulse test: Pulse width ≤ 300μs, Duty cycle ≤ 2%.

N-Channel Typical Characteristic Curves (CMS3586A6-HF)

Fig.1 - Typical Output Characteristics

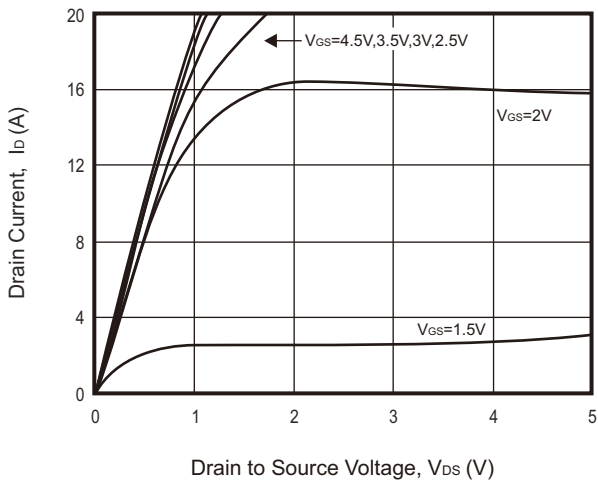

Fig.2 - Static Drain-Source On-State Resistance VS. Drain Current

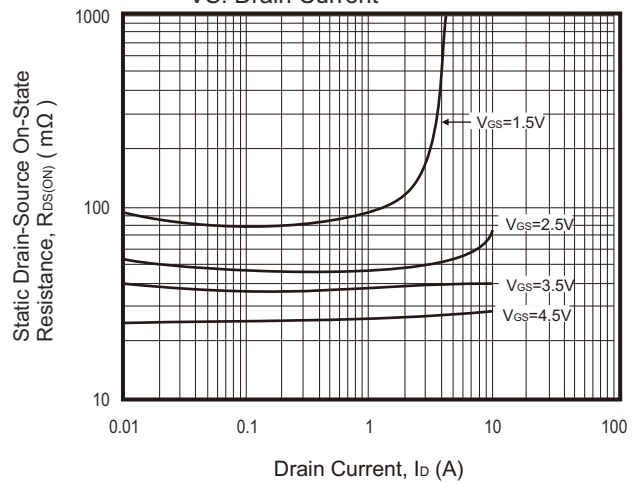

Fig.3 - Static Drain-Source On-State Resistance VS. Gate-Source Voltage

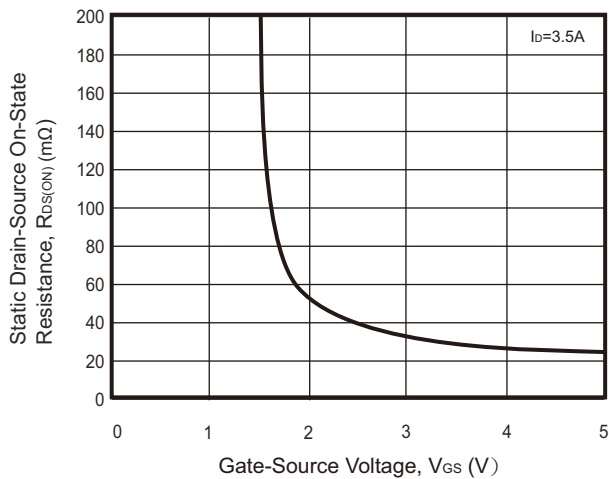

Fig.4 - Capacitance VS. Drain-Source Voltage

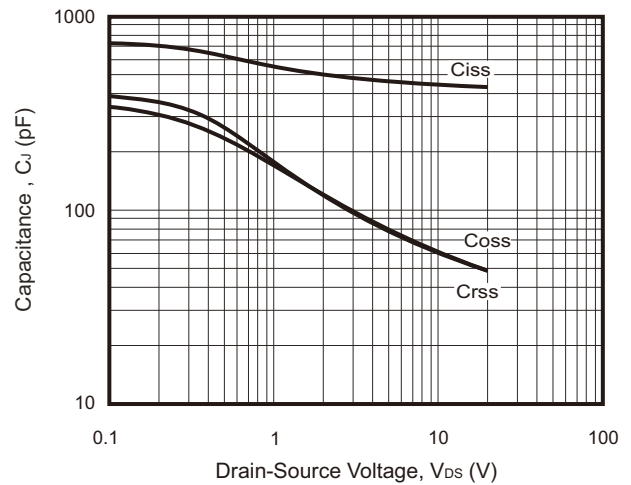
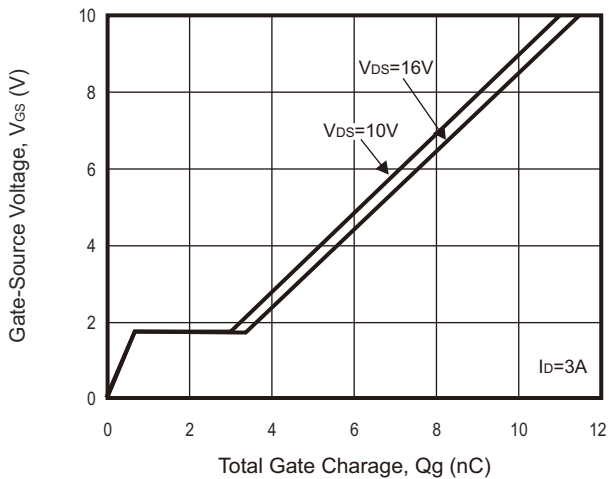

Fig.5 - Gate Charge Characteristics



P-Channel Typical Characteristic Curves (CMS3586A6-HF)

Fig.1 - Typical Output Characteristics

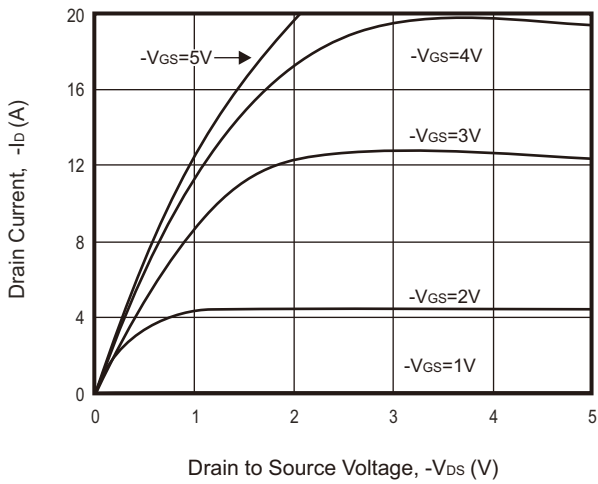

Fig.2 - Static Drain-Source On-State Resistance VS Drain Current

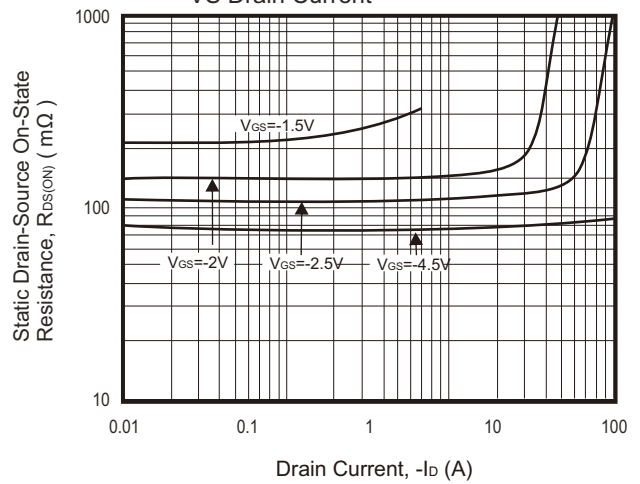

Fig.3 - Static Drain-Source On-State Resistance VS. Gate-Source Voltage

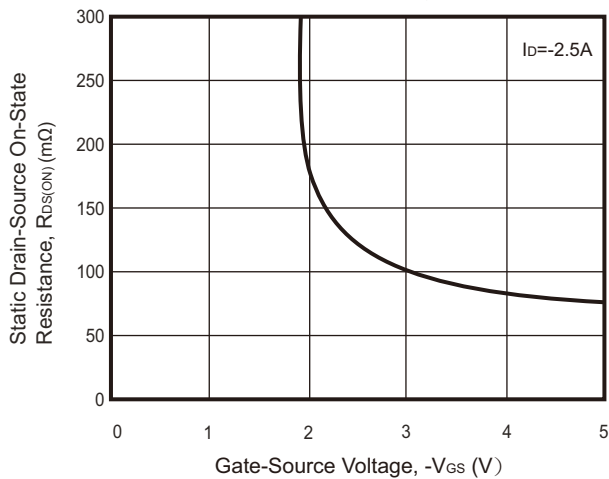

Fig.4 - Capacitance VS Drain-Source Voltage

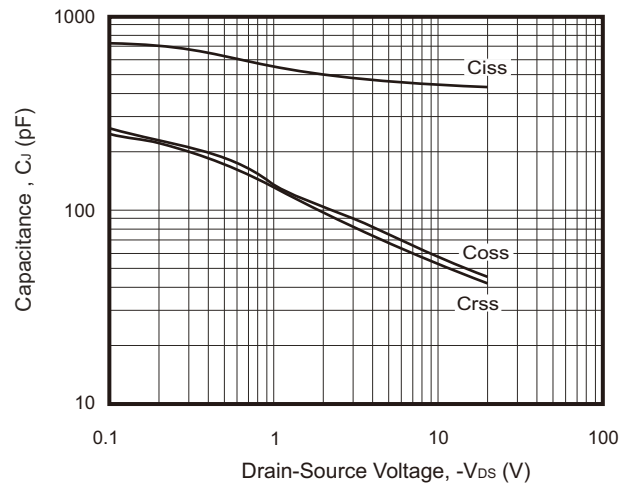
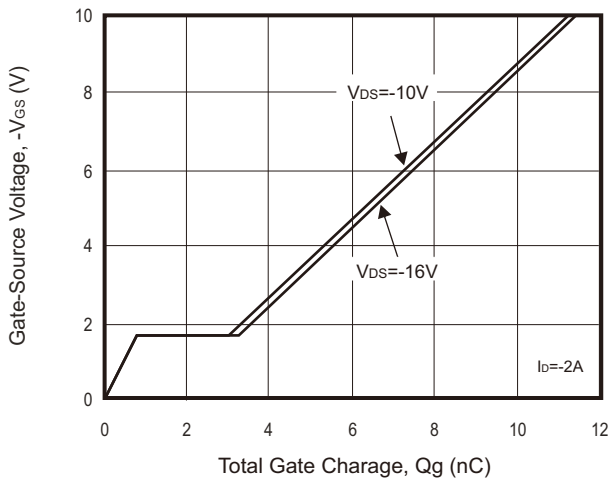
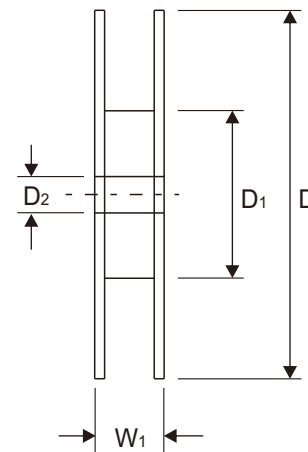
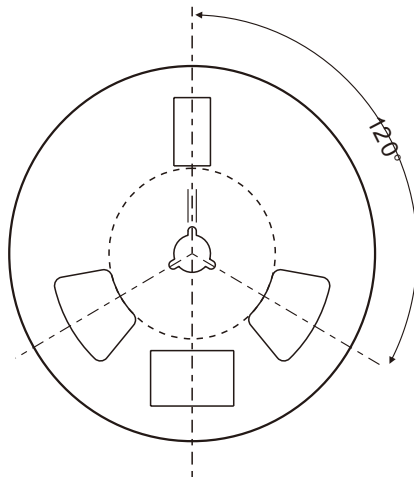
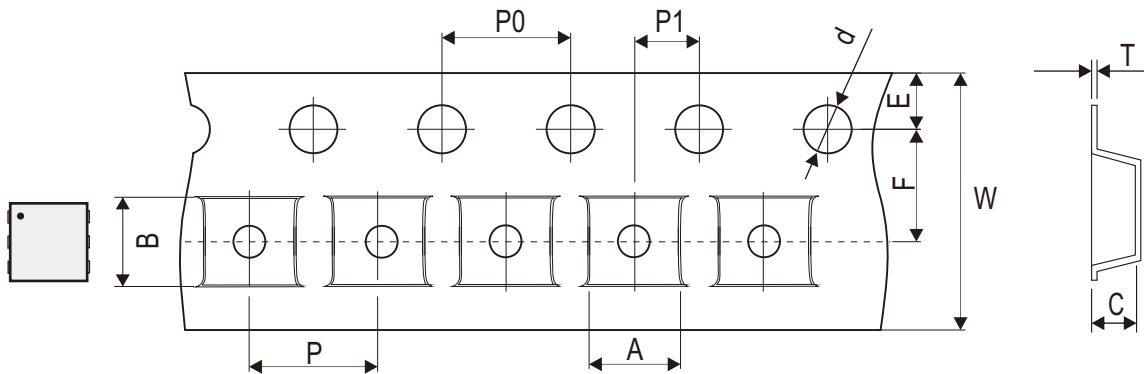

Fig.5 - Gate Charge Characteristics



Reel Taping Specification



DFN2X2-6L	SYMBOL	A	B	C	d	D	D1	D2
	(mm)	2.30 ± 0.05	2.30 ± 0.05	1.10 ± 0.05	1.50 + 0.10 - 0.00	180.00 + 0.00 - 3.00	60.00 ± 0.50	13.00 ± 0.20
	(inch)	0.091 ± 0.002	0.091 ± 0.002	0.043 ± 0.002	0.059 + 0.004 - 0.00	7.087 + 0.00 - 0.118	2.362 ± 0.020	0.512 ± 0.008

DFN2X2-6L	SYMBOL	E	F	P	P0	P1	T	W	W1
	(mm)	1.75 ± 0.10	3.50 ± 0.05	4.00 ± 0.10	4.00 ± 0.10	2.00 ± 0.05	0.27 ± 0.02	8.00 + 0.20 - 0.10	13.10 ± 1.30
	(inch)	0.069 ± 0.004	0.138 ± 0.002	0.157 ± 0.004	0.157 ± 0.004	0.079 ± 0.002	0.011 ± 0.001	0.315 + 0.008 - 0.004	0.516 ± 0.051

Marking Code

Part Number	Marking Code
CMS3586A6-HF	586B XXXX

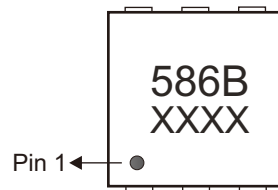

XXXX = Control code

Suggested P.C.B. PAD Layout

SIZE	DFN2X2-6L	
	(mm)	(inch)
A	1.70	0.067
B	0.85	0.033
C	1.10	0.043
D	1.40	0.055
E	2.00	0.079
F	0.40	0.016
G	0.65	0.026
H	0.30	0.012
I	0.77	0.030
J	0.16	0.006

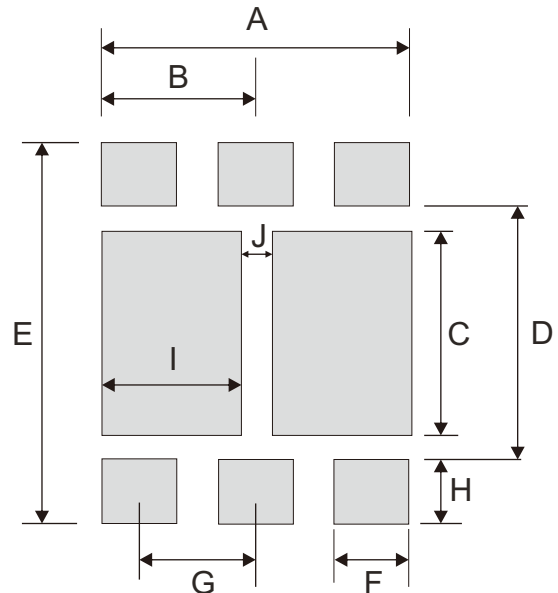

Standard Packaging

Case Type	REEL PACK	
	REEL (pcs)	Reel Size (inch)
DFN2X2-6L	3,000	7